

**NEW**

# Miniature Plane-Mirror Differential Interferometer

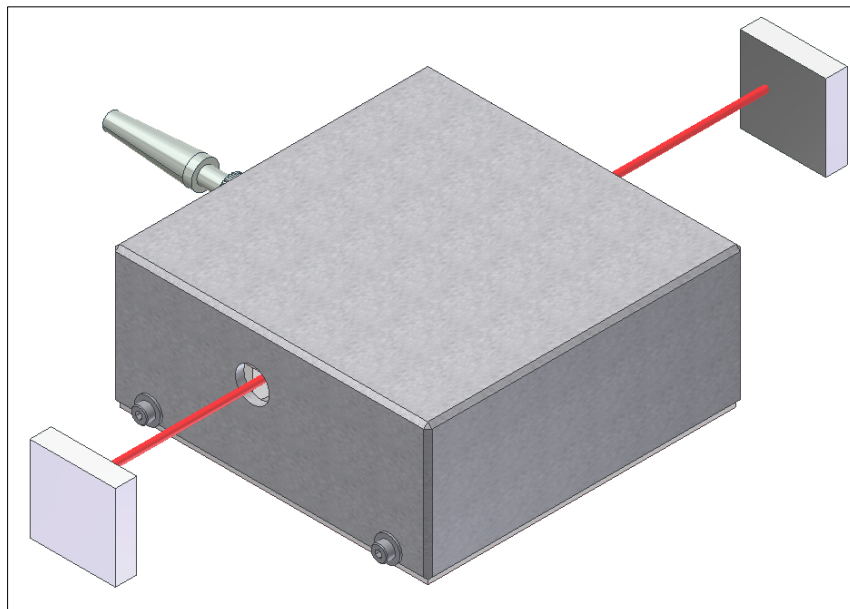

**SP-DIS - Series**

## Design and Operation

Our SP-Series miniature plane-mirror interferometers are precision length measurement instruments designed for incorporation into customer's OEM systems, and are easily adapted to suit a wide variety of experimental setups and tasks. The fiber optic feed durable miniaturized sensor head allows for their use as permanently mounted measurement sensors.

Planar mirrors or other optical-quality reflective surfaces may be employed as reflectors. The measuring arms are insensitive to misalignment by as much as several minutes of arc with respect to the laser beam without adversely affecting the operation of the interferometer making them easy to set up and use. The beam from the laser light source is transmitted to the sensor head by a fiberoptic cable.

Motion either of the planar mirrors analog the optical axis causes changes in the interference pattern, these changes are monitored in the sensor head and electrical signals are relayed to the signal processing/power supply unit for analysis and subsequent length measurement output.

Instrument operation and display of measurement results are controlled either through a separate keypad/display unit or a USB connected PC running optional software.

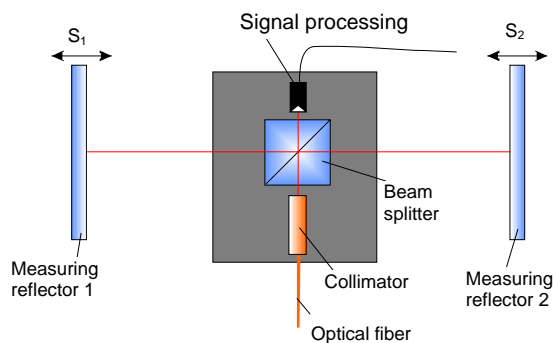

## Major Performance Features

- Ultraprecise length measurement instruments
- Single beam design minimizes Abbe aberrations when correctly aligned
- Versatile instruments for incorporation into customer supplied systems, readily adapted to suit a wide variety of tasks
- Fiberoptic coupled sensor head
- A planar mirror or other reflective surface may be employed as the moving reflector
- The specimen can be moved perpendicular to the direction of measurement depending on the measuring reflector dimensions
- Employs frequency-stabilized HeNe lasers as light sources
- Corrects for variations in laser wavelength caused by ambient conditions
- Sensor head material selectable between aluminium, stainless steel and Invar

## Applications

- Measurement and calibration of mirror surface
- Extensive position insensitivity of the sensor head
- Parallelism measurements
- Measurement against a fixed reference

Technical Data		Model SP 2000 DIS
Measurement range	mm	2,000
Metric resolution, optionally	nm	0.1
Nominal laser wavelength	nm	632.8
Laser frequency stability (after warm-up)		$2 \cdot 10^{-8}$
Laser warm-up period	min	10 - 20
Operating temperature range	°C	15 - 30
Maximum mirror translation rate	mm/s	800
Dimensions (H x W x D):		
Sensor head	mm	36 x 70 x 70
Optoelectronic signal-processing/power-supply unit	mm	150 x 450 x 400
Mass:		
Sensor head	g	200
Optoelectronic signal-processing/power-supply unit	g	9,500
Interface:		RS 232 C, USB Digital 32-bit parallel interface Digital increment signals (TTL) Analog increment signals ( $\pm 1 V_{pp}$ )
Fiberoptic cable length	m	3, optionally up to 10
Supply-line voltage	VAC	100 - 240
Supply-line frequency	Hz	47 - 60

## SIOS Meßtechnik GmbH

Am Vogelherd 46

D-98693 Ilmenau, Germany

Tel: +49-(0)3677-64470

E-mail: info@sios.de

Fax: +49-(0)3677-64478

URL: http://www.sios.de

Your contact for further information: