

Laser Rod Test Station

Centration and Wavefront Measurement of Laser Rods

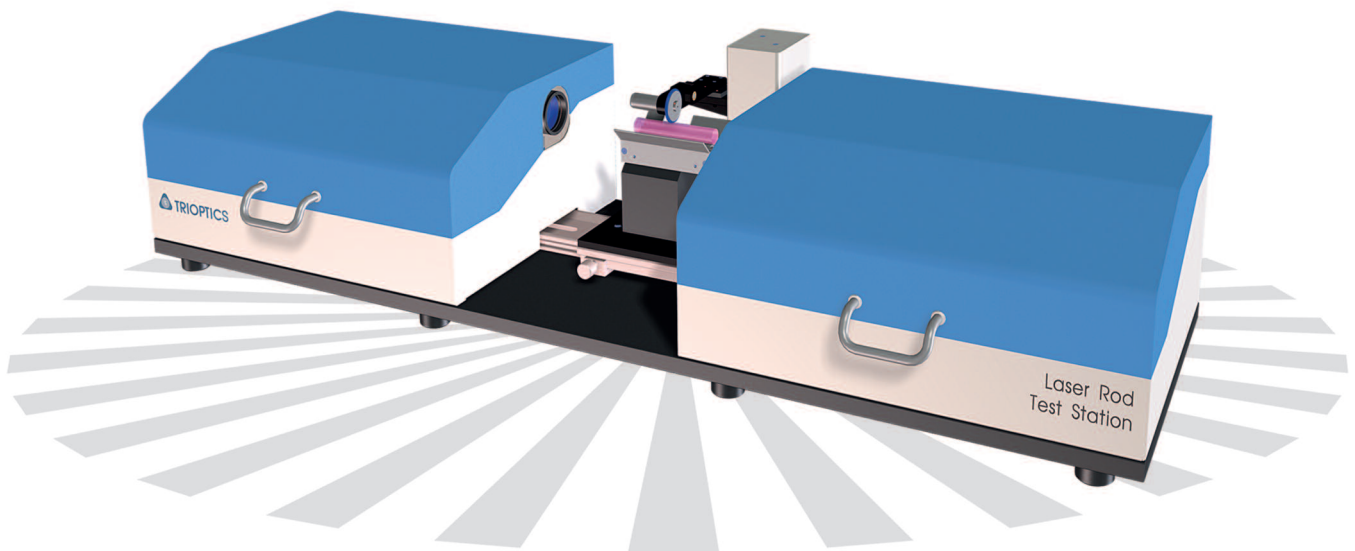

The quality of laser rods is mainly influenced by the parallelism of laser rod end surfaces and the homogeneity of the material. Ideally the light beam entering the laser rod should exit without deflection or adding wavefront aberrations.

The Laser Rod Test Station was developed for the quality control of laser rods. Its setup is horizontal in order to allow the precise rotation of long laser rods up to 150 mm. The system measures the position of both end surfaces

of a laser rod using two autocollimation measurement heads, like they are used with OptiCentric®. Furthermore it measures the transmitted wavefront of the laser rod with a WaveSensor®, a Shack-Hartmann sensor.

If the two end surfaces of the laser rod are not parallel and perpendicular to the cylinder axis, the traversing laser beam will be deflected. Similarly, defects in the material contribute to the beam deflection and wavefront aberrations.

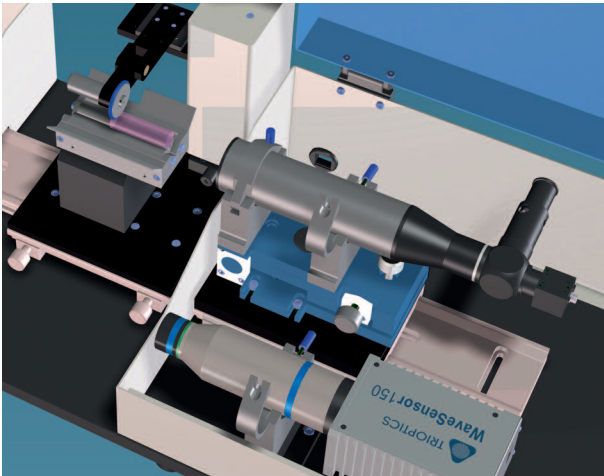

Autocollimation measurement head measuring the laser rod

The main parameters to be checked are:

- The parallelism of the laser rod end surfaces
- The beam deviation through the laser rod
- The position of optical end surfaces of the laser rod with respect to the cylinder axis
- Transmitted wavefront
- Material imperfections

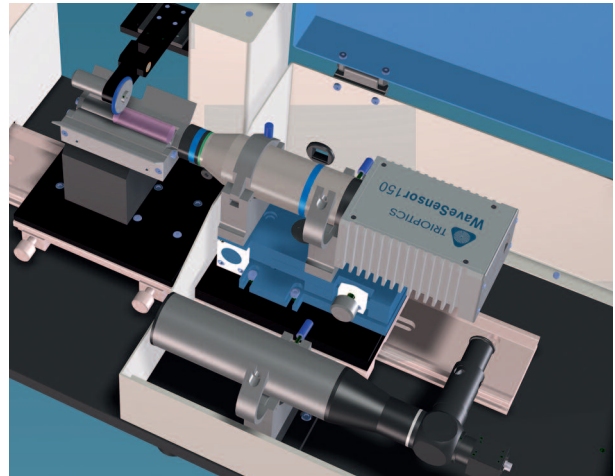

Wavefront sensor measuring the laser rod

The system works with OptiCentric® software, a special software module controls the centration measurement of the laser rods and provides specific data sets and measurement certificates. The wavefront measurement is controlled by the software for WaveSensor®.

Technical Data

	Unit	
Centration measurement		
Max. Dimensions of laser rod (l×ø)	mm	150 x 20
Measurement accuracy of the autocollimator	arc sec	1.3
Resolution	arc sec	0.05
Repeatability	arc sec	0.12
WaveSensor® 150		
Sensor area	mm	15×15
Lateral resolution	Number of micro lenses	138x138
Wavefront accuracy	λ	<1/20 (RMS)
Dynamic range	λ	>2000
Wavelength	nm	405-1100